

Numerical simulation of Steel-concrete composite joints at Elevated temperature

Results of on-going Compfire project



Naveed Iqbal
Tim Heistermann
Milan Veljkovic
Structures In Fire Forum (STiFF)
London, 12/04/2011

Outline

- Detailed Description of FE-Model
- Results from FE-Analyses
- Conclusions
- Future work

Description of FE-Model-Element types

Element types:

Two different types of Continuum elements have been used

- C3D8R
 - First order reduced Integration Elements
 - Reduced running time
 - Problems with hourglassing (zero energy modes)
- C3D8I
 - First order elements, enhanced by incompatible modes
 - Removes 'Parasitic shear strain energy' in bending
 - Expensive in terms of computation time
 - No hourglass modes

Description of FE-Model-Temperature distribution

Temperature distribution through the connection assembly:

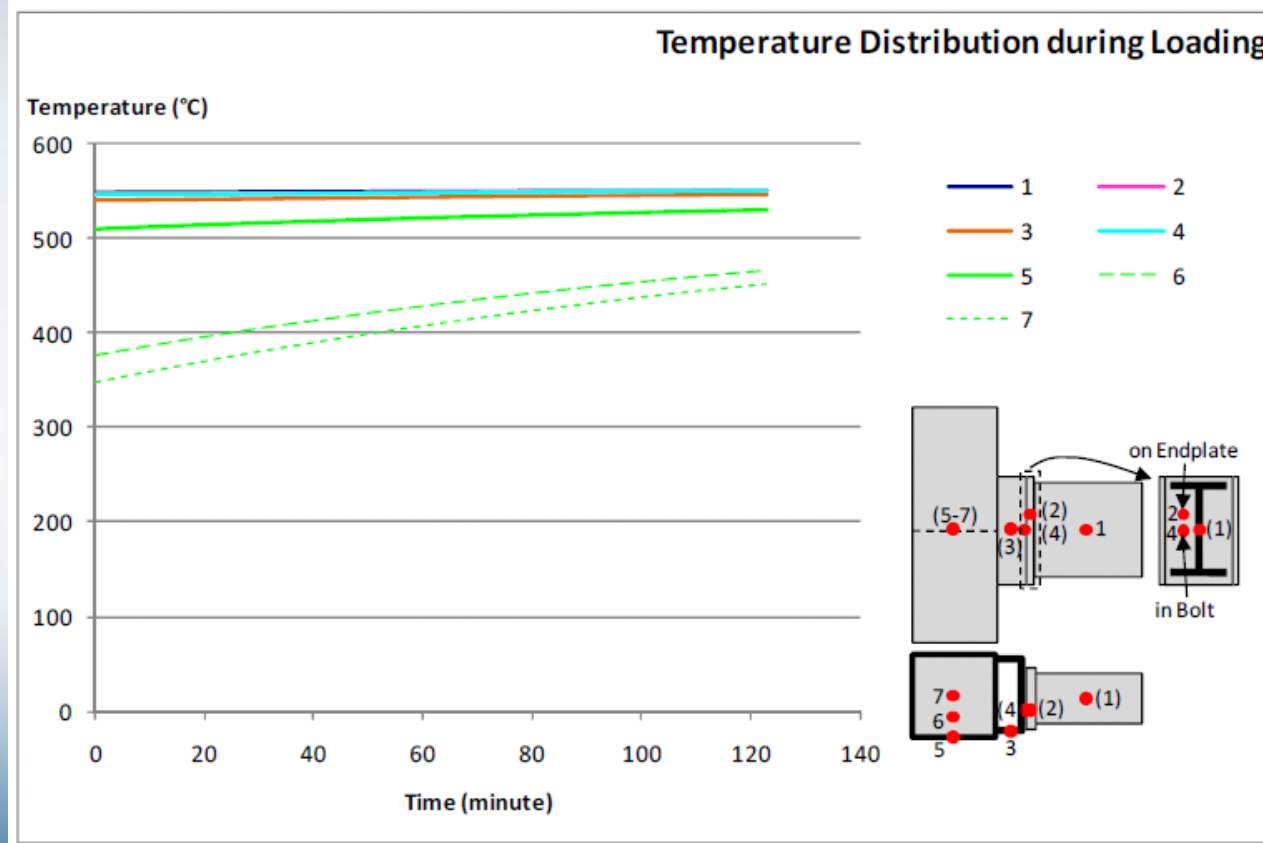

Source: <http://fire-research.group.shef.ac.uk>

Description of FE-Model-Temperature distribution

Temperature distribution through the connection assembly:

Temperature is applied as Predefined field in ABAQUS in each part of the connection assembly according to the temperature data from the test. The temperature is uniformly distributed through each part of the assembly i.e. the Connection components, The steel tube and the concrete thus assuming steady state conditions

Description of FE-Model-Loading mechanism

Loading mechanism used in furnace tests:

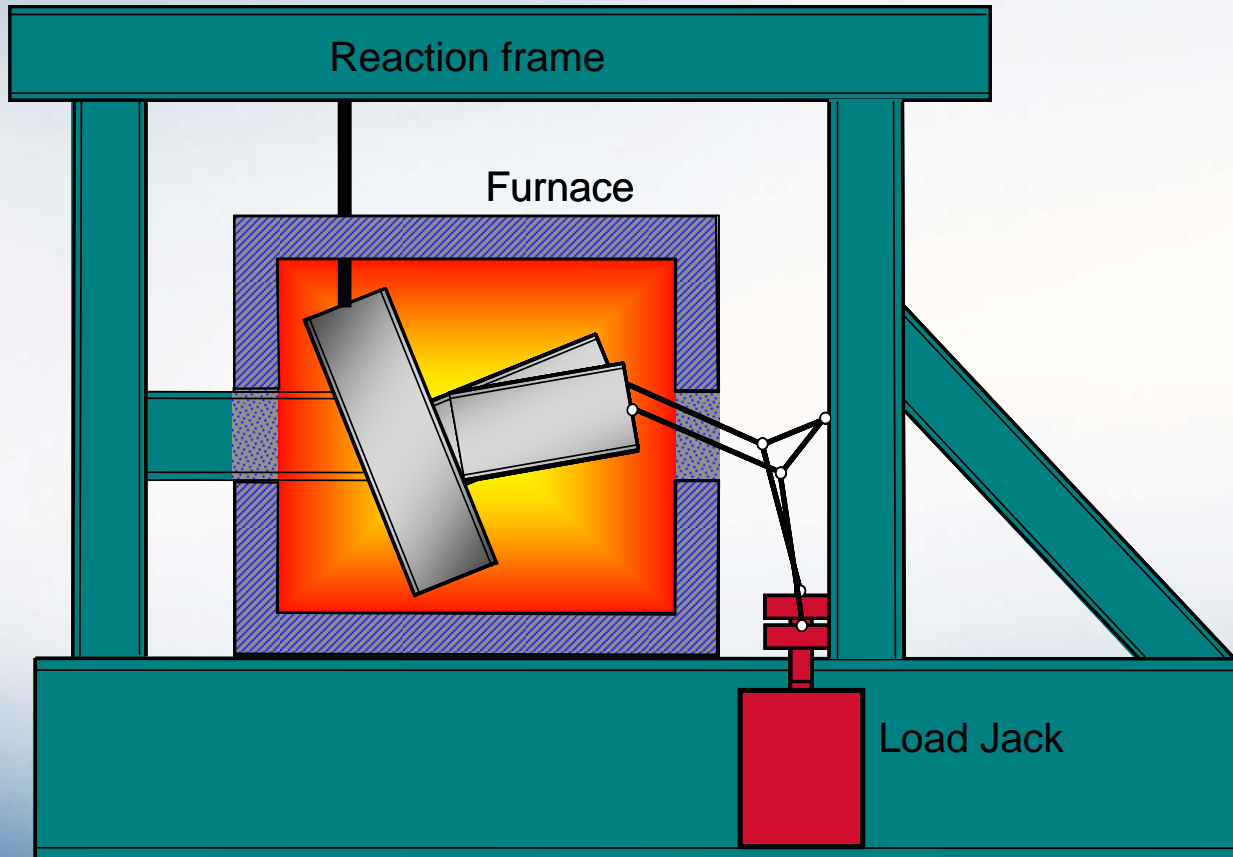

Source: <http://fire-research.group.shef.ac.uk>

Description of FE-Model-Loading mechanism

Loading mechanism used in FE-Model:

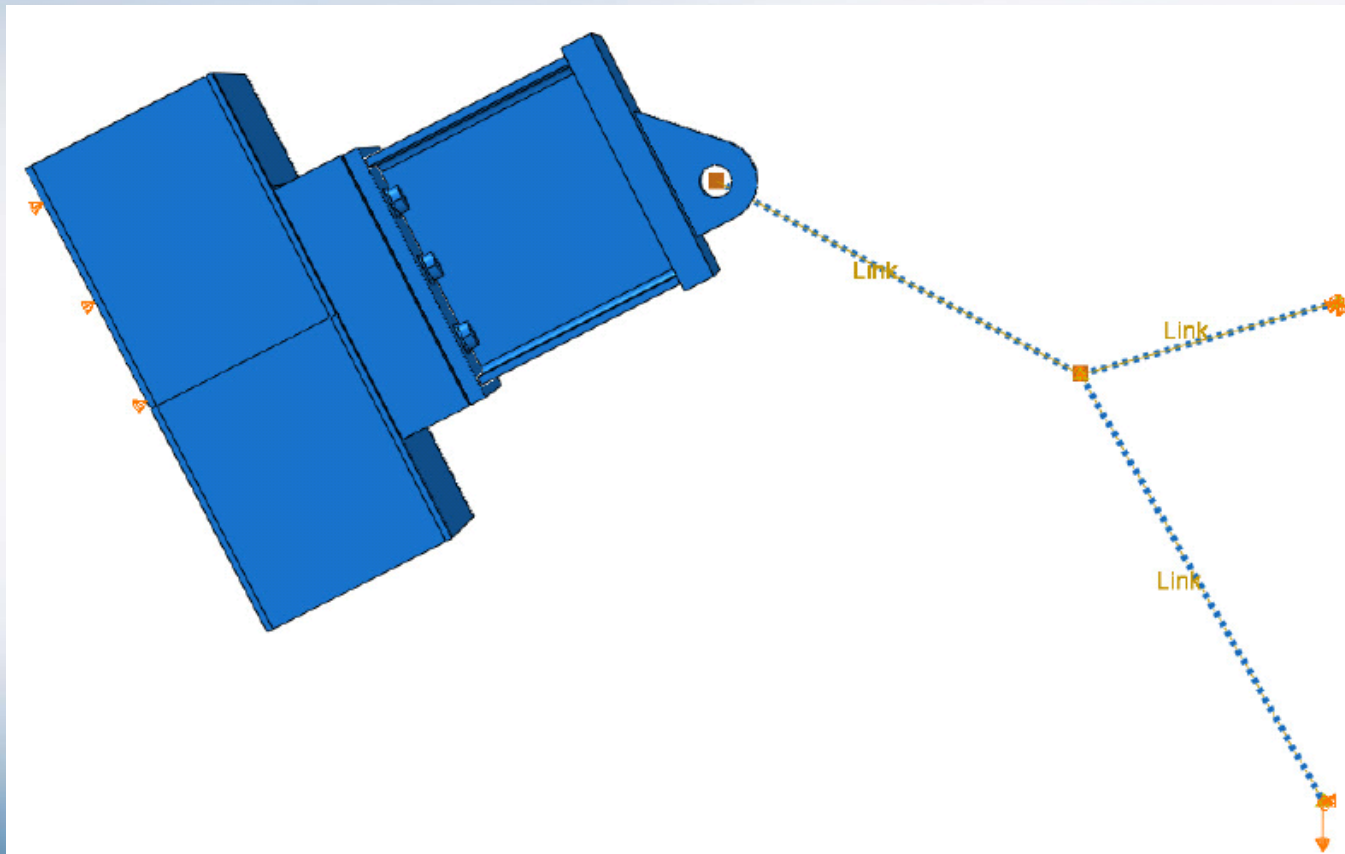

Description of FE-Model-Surface Interactions

- Surface to surface contact interaction
 - Standard surface to surface contact interaction
 - For all the contact surfaces except between the steel tube and concrete
- Tie constraints
 - Tie constraints used between all welded surfaces (Rigid connection is assumed)
 - Surface interaction between the inner surface of the steel tube and the concrete column is also modeled using tie constraint

Description of FE-Model – Analyses steps

General procedure:

- Initial step
 - ambient temperature (20°C) application (predefined field)
- First step
 - small pre-tensioning of bolts
 - > initialise contact
- Second step
 - Applying the temperature as a predefined field
- Third step
 - applying mechanical load through loading device

Results- Bolt force

A comparison between the characteristic tensile resistance in the bolt is made between Eurocode and FE-Model

•According to EN 1993-1-8

–Tension design resistance of individual bolt:

$$F_{t,Rd} = \frac{k_2 f_{ub} A_s}{\gamma_{M2}}$$

–The reduction factor k_2 and partial factor γ_{M2} when taken equal to one to get the characteristic resistance and multiplying it by the reduction factor $k_{b,\theta}$ for elevated bolt temperature from EN 1993-1-2 gives:

$$\text{–At } 550^\circ\text{C} \quad k_2 f_{ub} k_{b,\theta} = 79.6\text{kN}$$

$$\text{–At } 650^\circ\text{C} \quad k_2 f_{ub} k_{b,\theta} = 31.6\text{kN}$$

–The bolt load calculated from the FE-Model is exactly the same

Results- Endplate connection to partially encased column

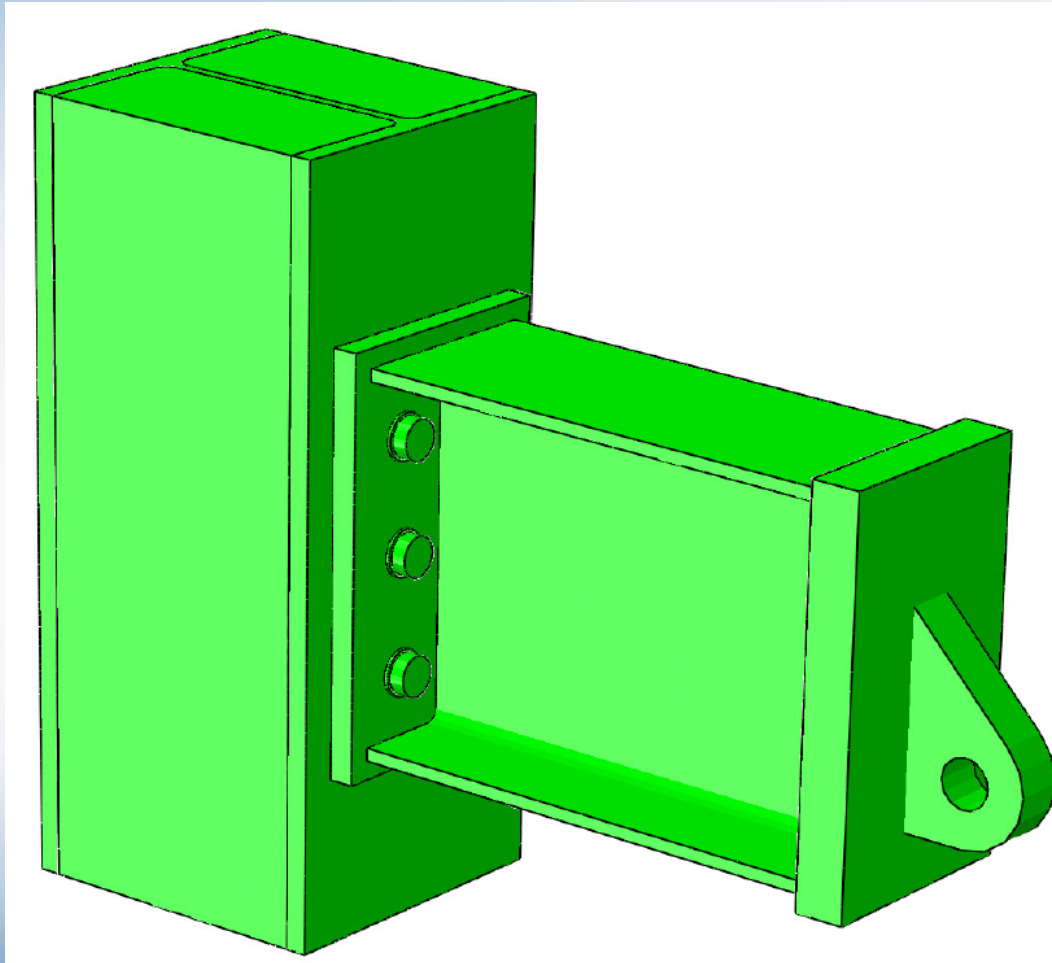

Results

Variation of forces in bolt rows for End-plate connection:

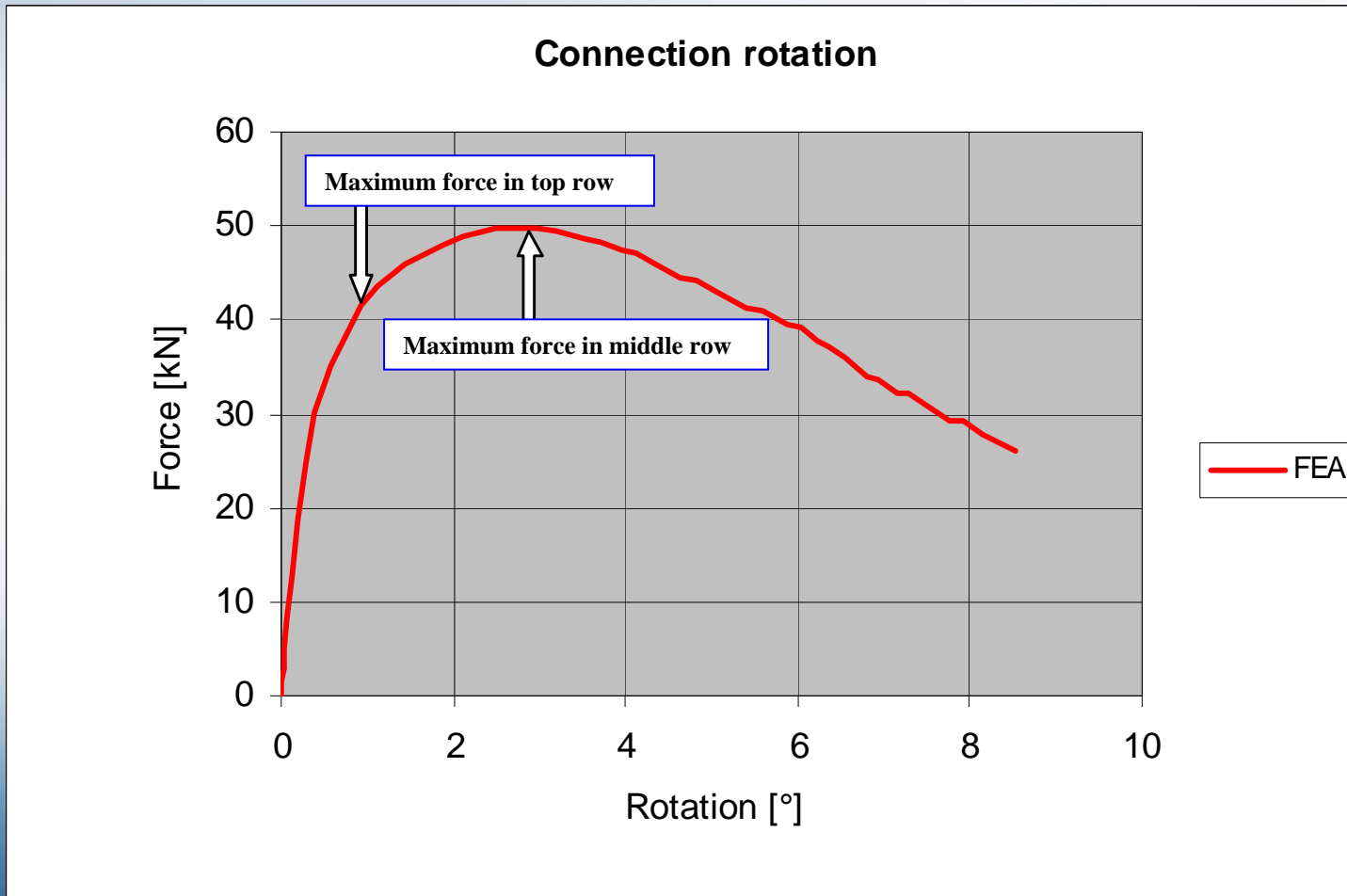

Results

Variation of forces in bolt rows for End-plate connection:

Increment	Upper bolts [kN]	Middle bolts [kN]	Lower bolts [kN]	Total force in oven bar [kN]
14	30.8	18.3	5.5	41.8
22	26.1	30.7	13.46	49.9

- Increment 14 corresponds to maximum force in upper bolts.
- Increment 22 corresponds to maximum resistance of connection.

Results

Contact pressure at the bottom of Endplate in Equilibrium with the bolt forces:

- Average contact pressure at ultimate load of the connection is 17 MPa
- The approximate contact area shown in the figure is around 8000 mm²
- The approximate total contact force obtained from the product of above two values is 136 kN
- Total sum of tensile force in the bolts at the same time is equal to 140 kN

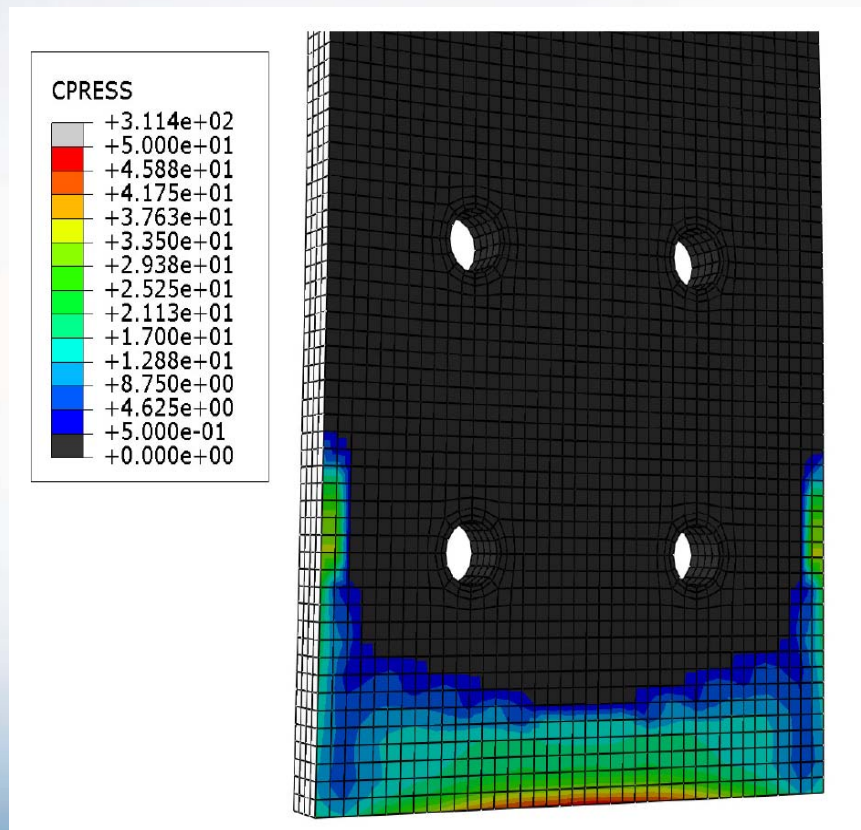

Results- Reverse channel connection to Square CFT column

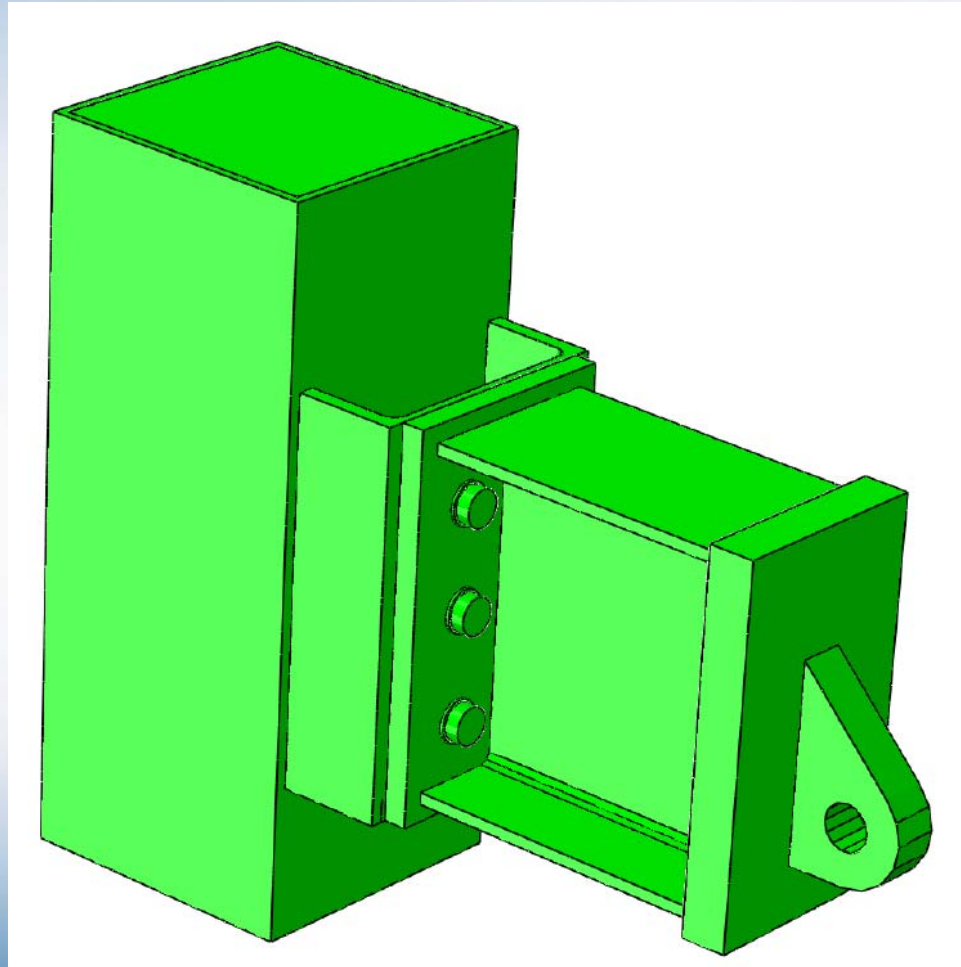

Results

Variation of forces in bolt rows and catenary action for a Reverse channel connection to square concrete filled tubular column:

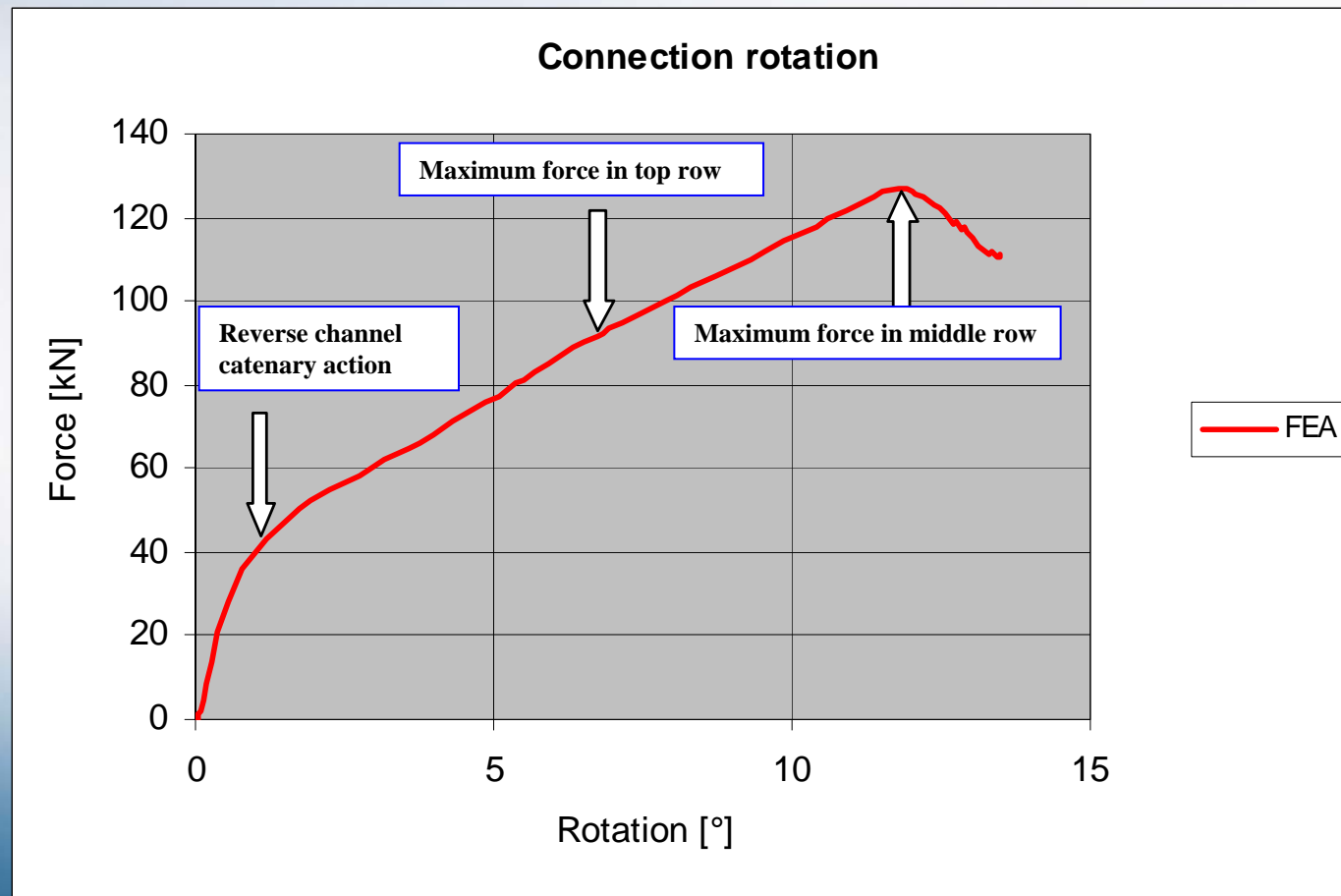

Results

Variation of forces in bolt rows for Reverse channel (UKPFC230) connection to square CFT column:

Increment	Upper bolts [kN]	Middle bolts [kN]	Lower bolts [kN]	Total force in oven bar [kN]
28	75.24	70.01	43.51	91.84
56	42.3	74.4	47.97	119.07

- Increment 28 corresponds to maximum force in upper bolts.
- Increment 56 corresponds to maximum resistance of connection.

Results- Failure Modes

Comparison between FE-Model and test for Endplate connection to Partially encased composite column (650°C):

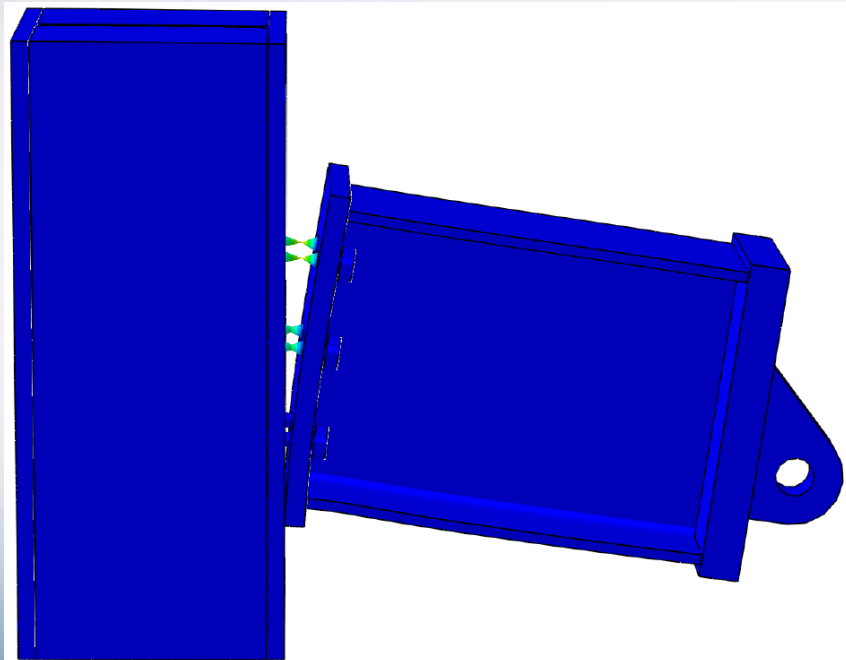

FE-Model



Test

Source: <http://fire-research.group.shef.ac.uk>

Results- Failure Modes

Comparison between FE-Model and test for Endplate connection to Partially encased composite column (550°C):

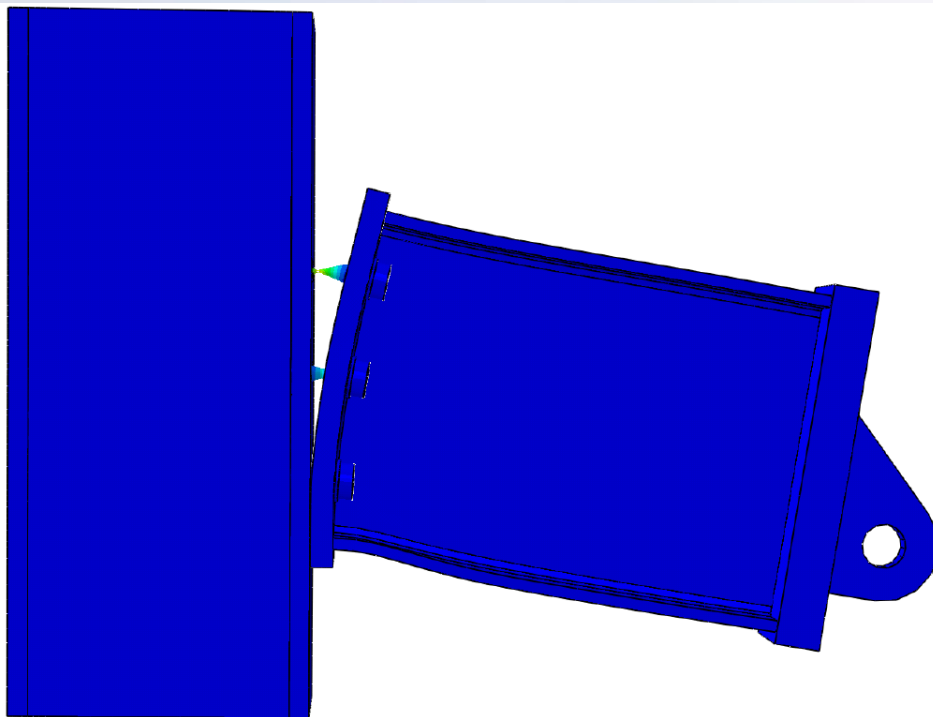

FE-Model



Test

Source: <http://fire-research.group.shef.ac.uk>

Results- Failure Modes

Comparison between FE-Model and test for Reverse channel connection to Square CFT column (550°C):

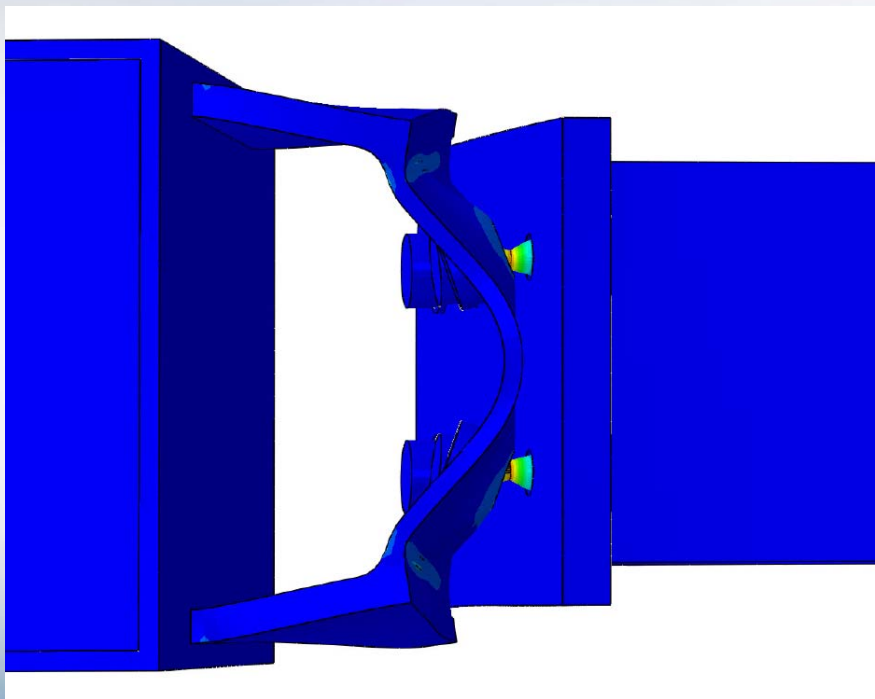

FE-Model



Test

Source: <http://fire-research.group.shef.ac.uk>

Results

Comparison between Load-vs-Connection rotation curves for FE-Model and Test, for Endplate connection to Partially encased composite column (650°C):

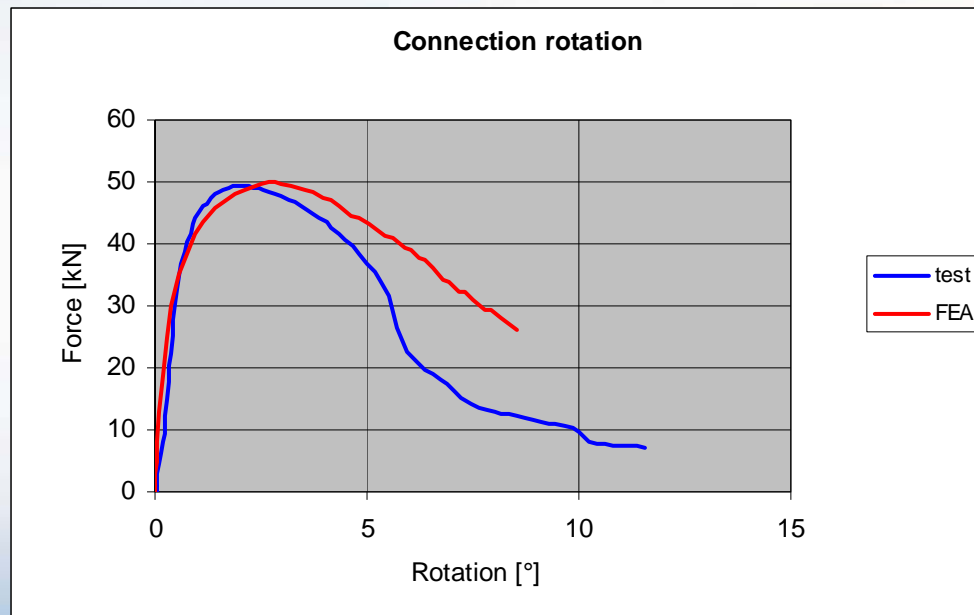

Results

Comparison between Load-vs-Connection rotation curves for FE-Model and Test, for Endplate connection to Partially encased composite column (550°C):
(Different failure modes between FE-Model and Test)

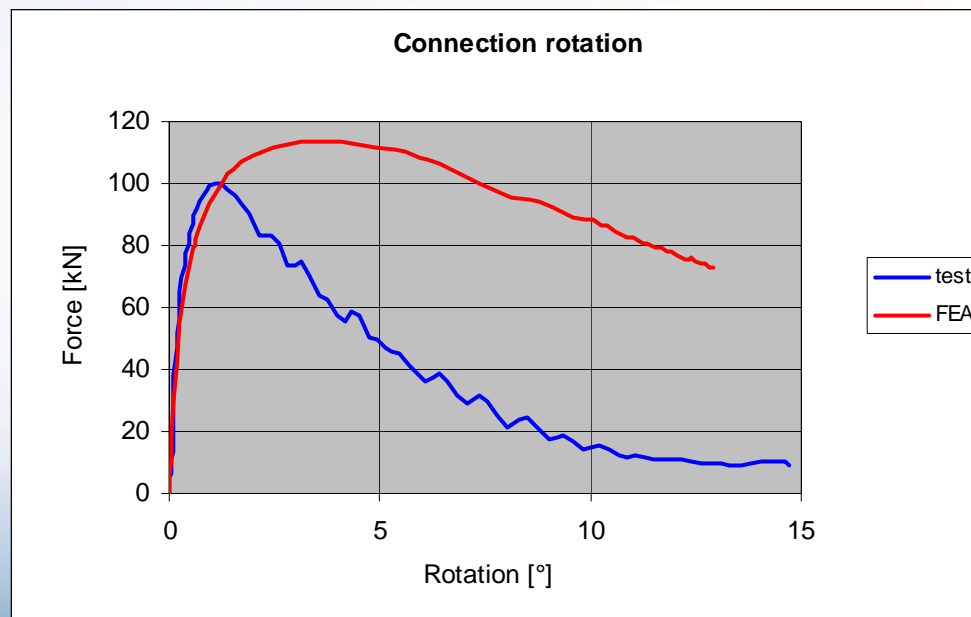

Results

Comparison between Load-vs-Connection rotation curves for FE-Model and Test, for Reverse channel (UKPFC230) to square CFT column (550°C):

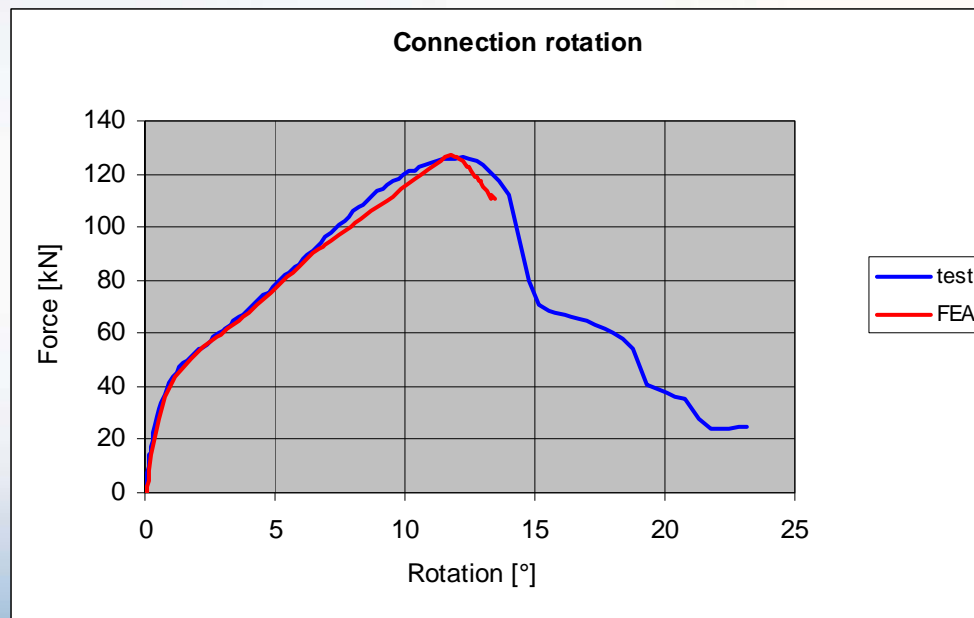

Results

Comparison between Load-vs-Connection rotation curves for FE-Model and Test, for Reverse channel (UKPFC200) to square CFT column (550°C):

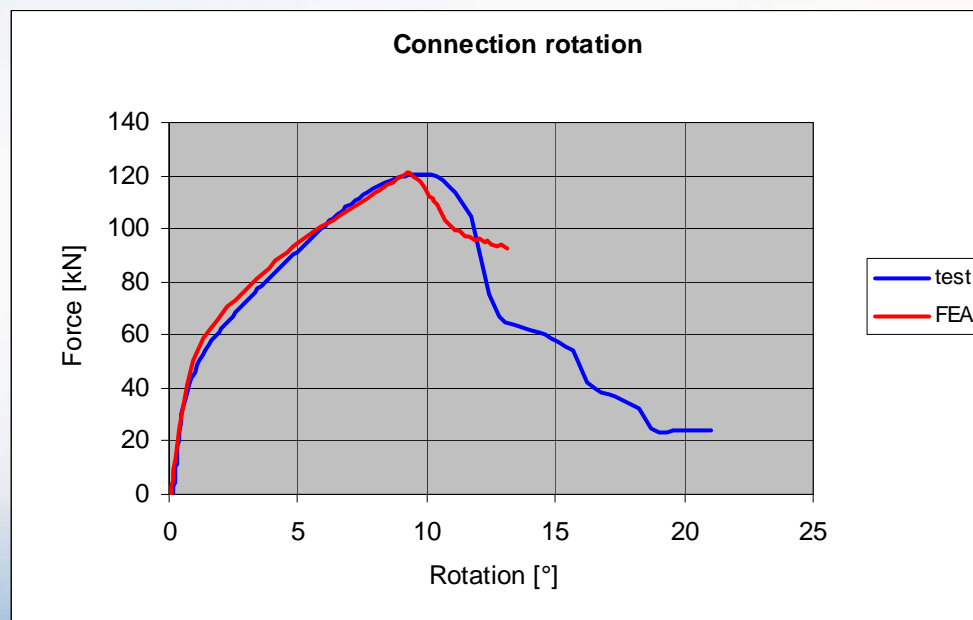

Results

Comparison between Load-vs-Connection rotation curves for FE-Model and Test, for Reverse channel (UKPFC180) to square CFT column (550°C):

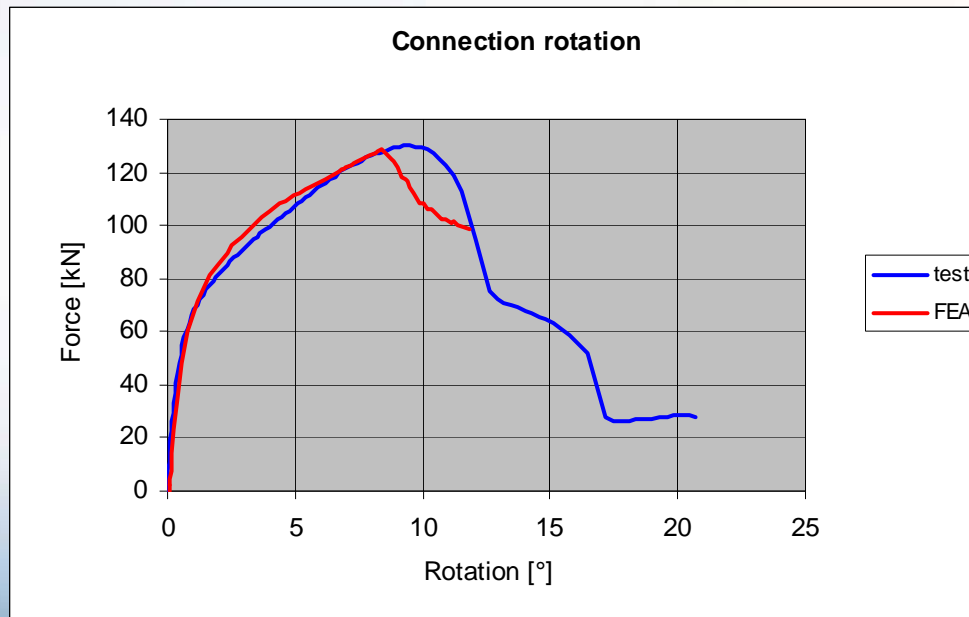

Results

Comparison between behaviour of the FE-Models of different connection types

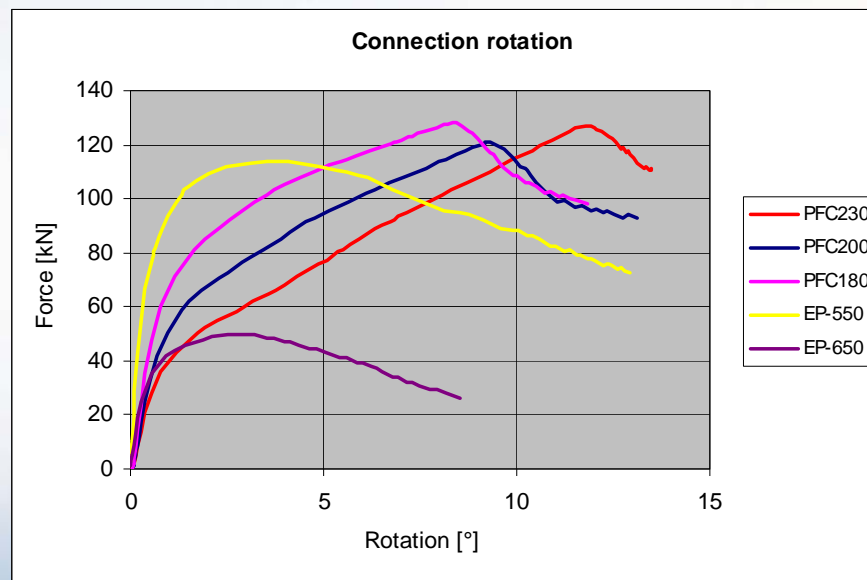

Conclusions

- successfully implemented:
 - mechanical contact behaviour
 - temperature dependent material behaviour
 - load application mechanism
- Close agreement between the stiffness behaviour of the FE-Model and the test is observed
- Similar failure modes are observed between the FE-Models and the test models
- In general Reverse channel connections exhibit a higher rotation capacity and hence a more ductile behaviour

Future work

These Finite Element models will be further used in carrying out Parametric studies and the results would be used to develop design guidelines for practical applications.

Acknowledgements



COMPFIRE – RFSR-CT-2009-00021



**Thank you for
your attention!**